

ATTACHMENT SCHEDULE	
POST TO BEAM	SIMPSON MODEL # LPC6 8-10D FASTENERS
POST TO FOOTINGS	SIMPSON MODEL # ABA66 8-10D FASTENERS
JOISTS TO BEAM	SIMPSON MODEL # LTS16 8-10D FASTENERS
JOISTS TO LEDGER	SIMPSON MODEL # LUS28 8-10D FASTENERS
LEDGER TO HOUSE	4" GALVANIZED LAG BOLTS AND WASHERS @ 16" O.C.

KEY	
	(3) 2"x10" GIRDER ON 6"x6" POST, FOOTING TO BE 36" BELOW GRD TYP
	SUNROOM

JOIST SCHEDULE		
SPAN	SPACING	SIZE
12'	16' O.C.	2"x10"
		SUNROOM

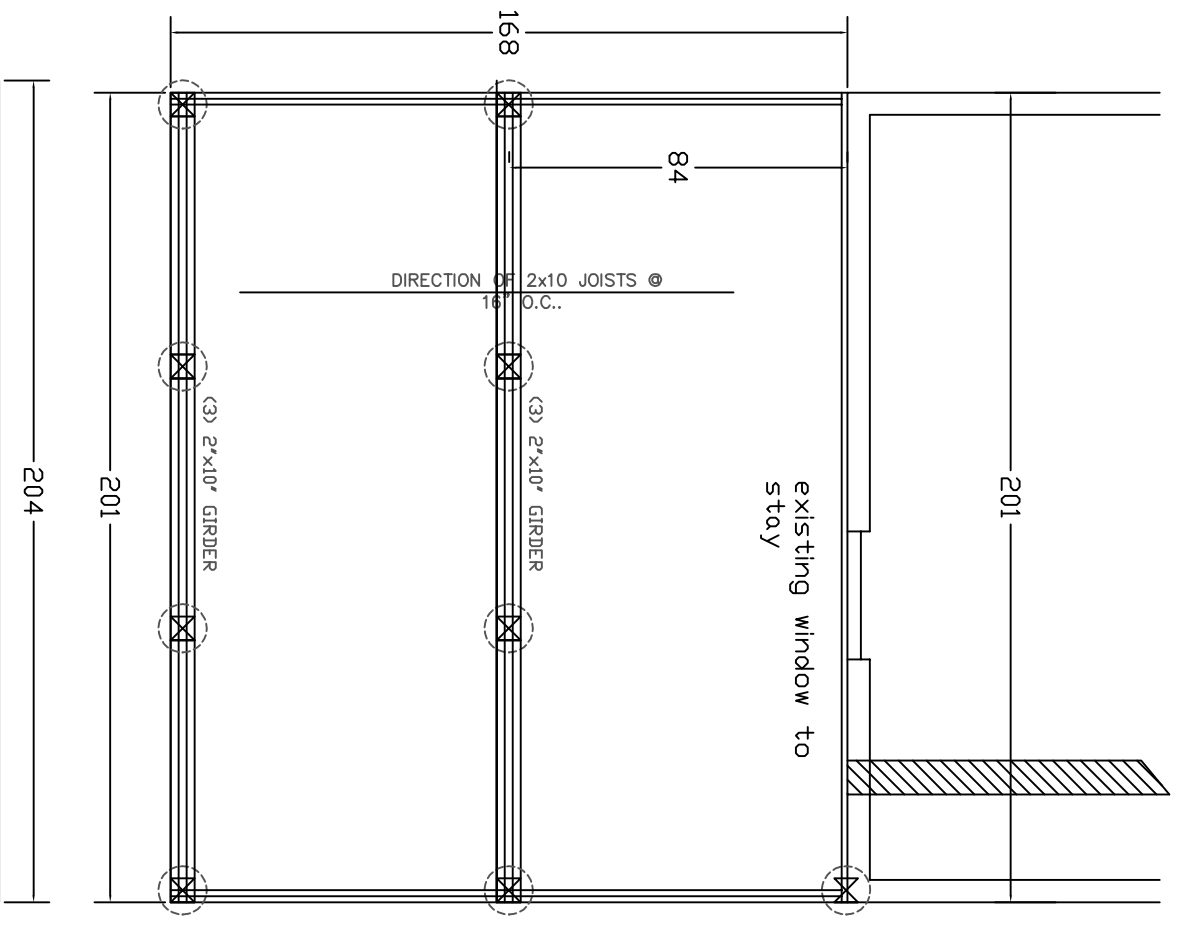
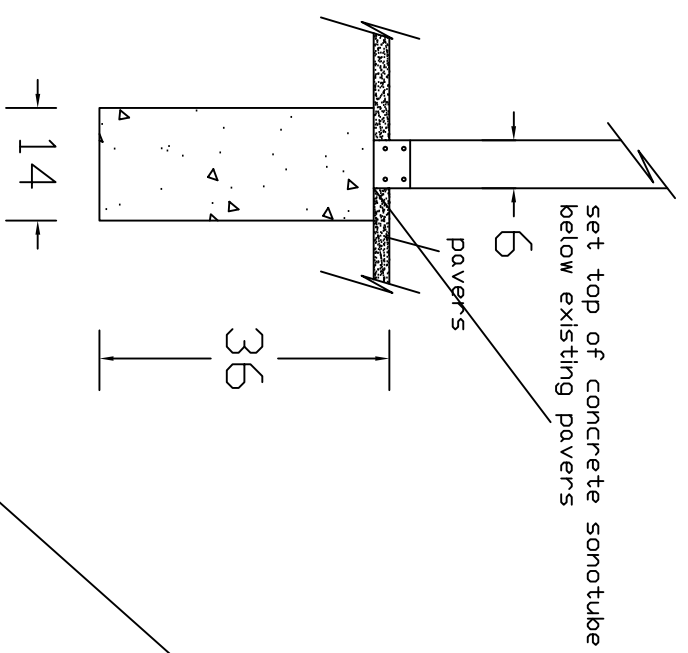

all lumber to be pressure treated

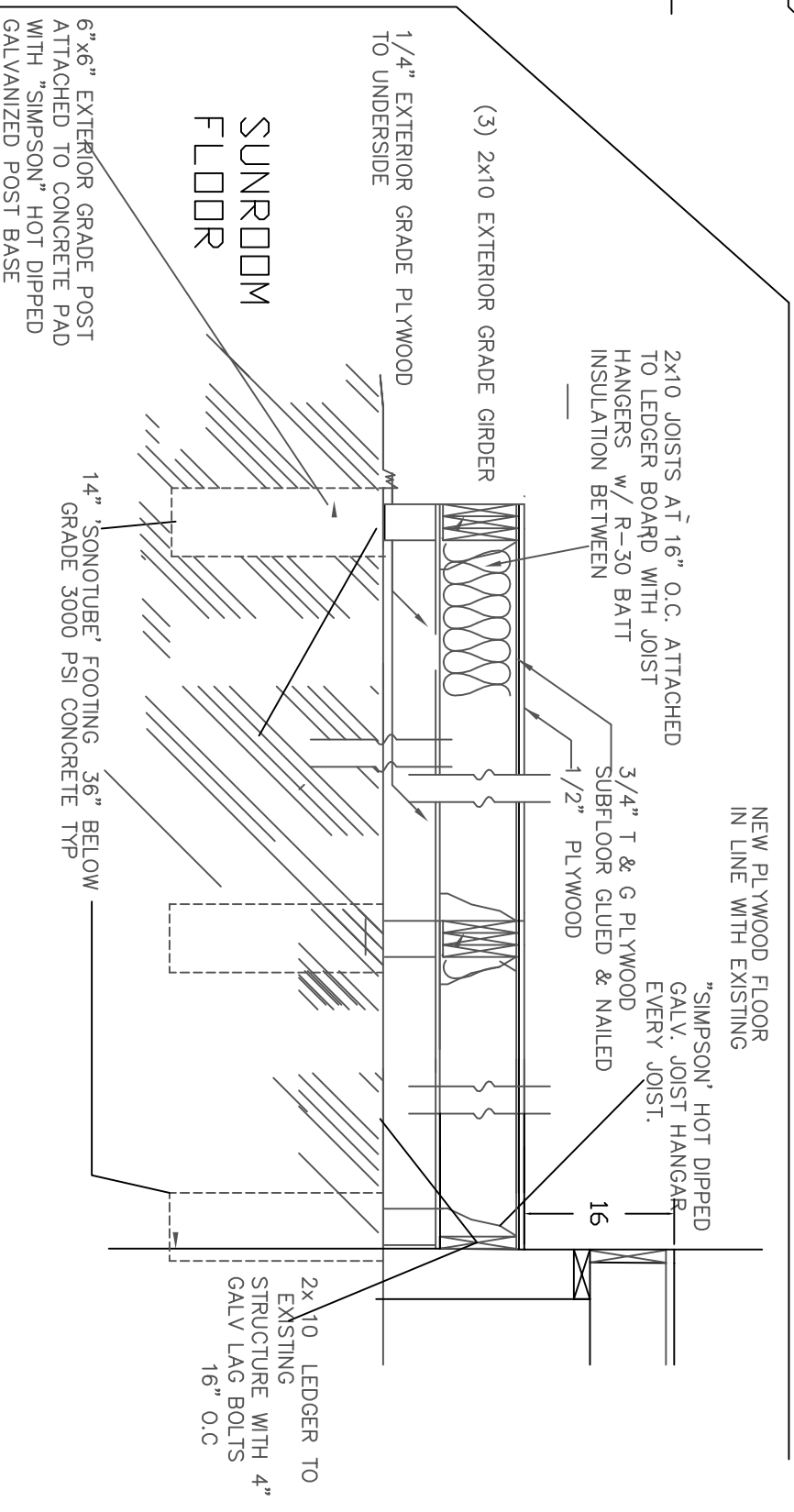

all lumber to be pressure treated

SCALE 1/4 inch = 4ft  
DATE

I / WE THE CUSTOMER HAVE CHECKED THE FINAL DRAWINGS, AND CONFIRM THAT THE DESIGN AND SIZES SHOWN ARE CORRECT AND NOW AUTHORISE NJSA TO PLACE MY ORDER INTO MANUFACTURE.  
SIGNED  
PRINT  
DATE

N.J.S.A.  
1199 Rt 22 EAST  
MOUNTAINSIDE  
N.J 07092

McCann RESIDENCE  
384 KNIERIM PL  
NEW MILFORD  
NJ

Lawrence Cirangle  
NJ License No 10677

CIRANGLE ARCHITECTS  
14, PLAZA NINE, MANALAPAN, NJ, 07726  
TEL - (732) 303 7822 CELL - (732) 303 7822  
FAX - (732) 303 7833 EMAIL - lcirangle@aol.com

A-4